

Preface





CAUTION: Please read this manual carefully, also with related manual for the machinery before use the controller. For installing and operating the controller properly and safely, qualified personnel are required.

This product is designed for specified sewing machines and must not be used for other purposes.

If you have any problem or any comment, please feel free to contact us.

Safety Instruction

- 1) All the instruction marked with sign  must be absolutely observed or executed; otherwise, personal injuries or risk to the machine might occur.
- 2) This product should be installed and operated by persons with appropriate training only.
- 3) Before connecting power supply cords to power sources, it's necessary to make sure that the power voltage is in the range indicated on the product name plate.
- 4) Make sure to move your feet away from the pedals while power on.
- 5)  Turn off the power and remove plug prior to the following operations:
 - Connecting or disconnecting any connectors on the control box;

- Repairing or doing any mechanical adjustment;
 - Threading needle or raising the machine arm;
 - Machine is out of work.
- 6) Make sure to fasten all the fasteners firmly in the control boxes prior to the operation of the system.
 - 7) Allow an interval of at least 30 seconds before repapering the system after power off.
 - 8) Repairs and maintenance work may be carried out by special trained electronic technicians.
 - 9) All the replacement parts for repairing must be provided or approved by the manufacturer.
 - 10) The controller must be firmly connected to a properly grounded outlet.

	CAUTION:	Be sure to connect the controller to a properly grounded outlet. If the grounding connection is not secured, you may run a high risk of receiving a serious electric shock, and the controller may operate abnormally.
---	-----------------	---

1. Product Introduction

1.1 Overview

These Series Digital AC Servo System, the motor and the controller are separately mounted on the same bracket, providing a very flexible mounting solution for customers. The system can be easily configured with different motors to match with various sewing machines, such as lockstitch, dual-needle lockstitch, heavy duty, and direct-driven sewing machines. The solenoid outputs are over current protected, preventing damage of the controller in case of mis-wiring of external accessories. Employing a switch-mode power supply for the sensitive control circuitry, the system can operate over a much wider voltage range. Side-mount connectors make the connection more reliable and reduce the malfunction caused by oil leakage.

1.2 Basic parameters

Basic parameters of Jk2000A series Digital AC Servo System (see table 1).

Table1:

Controller Type	AS58-DB37			
Max. Sewing Speed (r/min)	5000		3000	
Voltage Range	AC 220±20% V 50/60HZ			
Output Power	550W		750W	
Max. Torque	3Nm		7Nm	
Environment	0°C ~ 40°C			
The motor way of transmission	Belt dirive	Direct drive	Belt dirive	Direct drive

2. Installation Instructions

2.1 Motor Installation

Step 1: Mount lifting bracket. When motor installed under the machine table, as needed, to drill holes in the following diagrams (see Fig. 2-1 the example for USA base table) for the installation, mount lifting bracket.

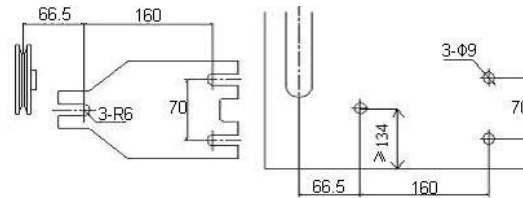

Fig.2-1

Step 2: Install the motor (see Fig.2-2) and then tighten the lifting bracket.

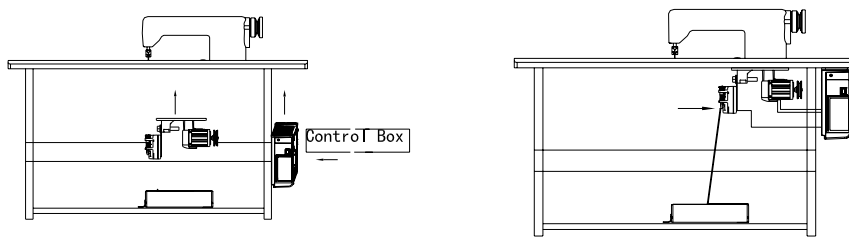

Fig.2-2

2.2 Controller Installation

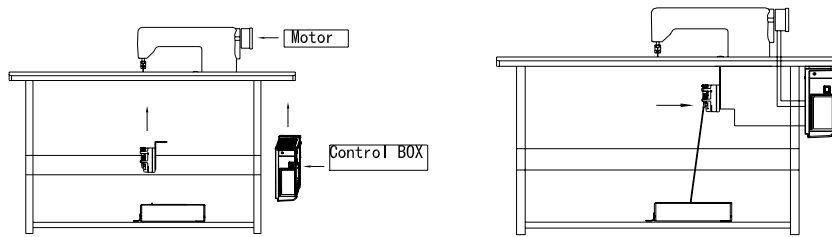

Fig.2-3

2.3 Controller shape dimension

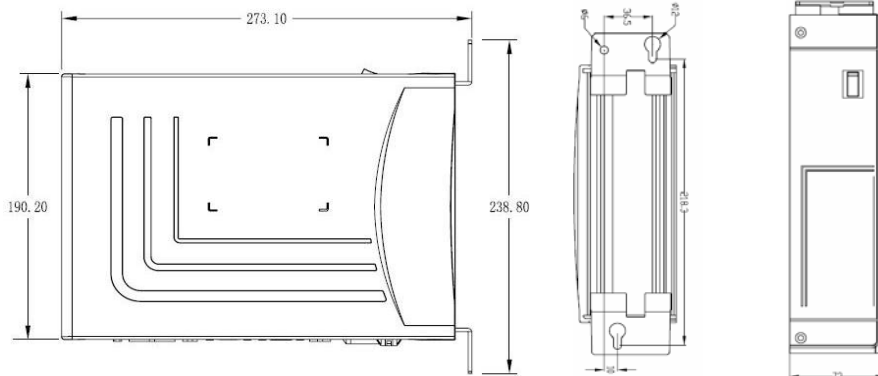

Fig.2-4

3. Power Connection and Grounding

Ground wire (Green/yellow) must be grounded. Use the correct connector and extension wire when connecting ground wire to Earth and secure it tightly (see Fig.3-1).

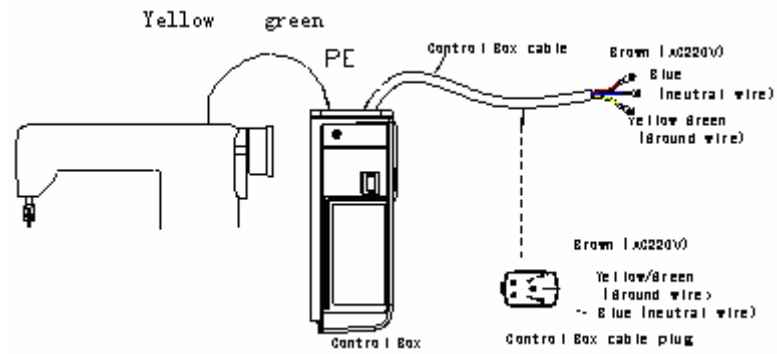

Fig. 3-1

 CAUTION	<p>Ensure all power cord, signal wire and grounding wire not be pressed by other matter or over-twisted ,and not be too close to belt and belt wheel, keep 3cm-distance for safety.</p>
--------------------	---

A 1Φ/220V power from a 3Φ/380V Power source Connection (See Fig.3-2):

 CAUTION	<p>If the system have no Neutral point, then this servo motor is not suitable for this connection.</p>
--------------------	--

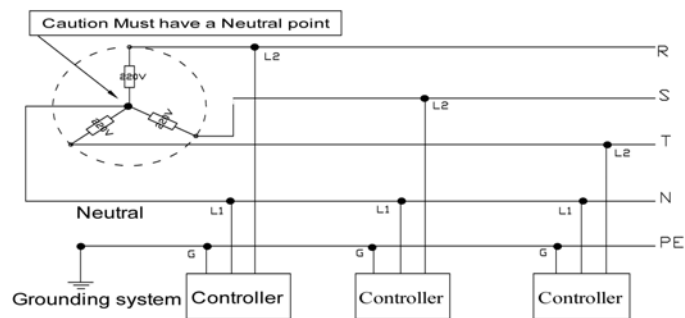

Fig. 3-2

4. Definition of controller interface

Connections between control box and other accessories are illustrated in Fig.4-1.
Plug these connectors into the corresponding sockets in control box.

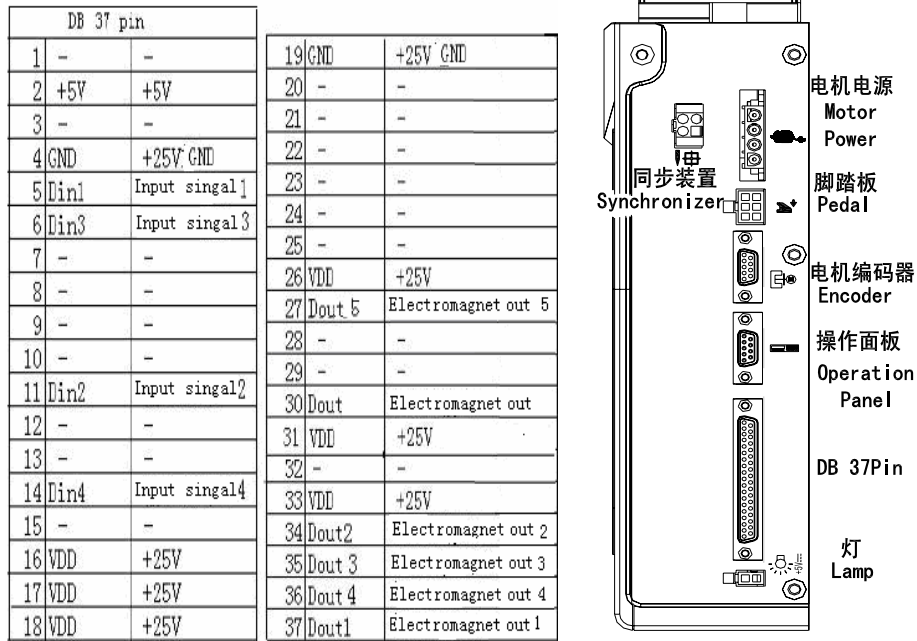

Fig. 4-1

The drive ability of the LED jack:

which the rated current is 20mA and the rated voltage is 3V.
Recommendatory LED diode parameter as follows:
VF: Min. = 3.0V, Max. = 3.6V (test condition IF = 20mA);
Peak Forward Current: Max. = 80mA;
Continuous Forward Current : Max. = 35mA



Caution:

Please check if all connectors match or not, pins are found right definition or not.

5. Recovery processing and maintenance

error code	meaning	solution
01	hardware overflow	Turn off the system power, restart after 30 seconds, if the controller still does not work, please replace it and inform the manufacturer.
02	software overflow	
03	system under-voltage	Disconnect the controller power and check if the input voltage is too low (lower than 176V). If yes, please restart the controller when the normal voltage is resumed. If the controller still does not work when the voltage is at normal level, please replace the controller and inform the manufacturer.
04	over-voltage when the machine is off	Disconnect the controller power and check if the input voltage is too high (higher than 264V). If yes, please restart the controller when the normal voltage is resumed. If the controller still does not work when the voltage is at normal level, please replace the controller and inform the manufacturer.
05	over-voltage in operation	
06	solenoid circuit failure	Turn off the system power, check if the solenoid is connected correctly and if it is loose or damaged. If yes, replace it in time. Restart the system upon making sure everything is in good order. If it still does not work, seek technical support.
07	electrical current checking circuit failure	Turn off the system power, restart after 30 seconds to see if it works well. If not, try several more times. If such failure happens frequently, seek technical support.
08	locked motor roller	Disconnect the controller power, check if the motor input plug is off, loose or damaged, or if there is something twined on the machine head. After checking and correction, if the system still does not work, please replace the controller and inform the manufacturer.
09	brake circuit failure	Turn off the system power, check if the white brake resistance plug on the power board is loose or dropped off, fasten it and restart the system. If it still does not work, please replace the controller and inform the manufacturer.
10	HMI communication failure	Check if the connecting line between control panel and controller is off, loose or broken, restore it and restart the system. If it still does not work, please replace the controller and inform the manufacturer.
11	machine head needle positioning failure	Check if the connection line between machine head synchronizer and controller is loose or not, restore it and restart the system. If it still does not work, please replace the controller and inform the manufacturer.
12	motor original angle checking failure	Please try 2 to 3 more times after power down, if it still does not work, please replace the controller and inform the manufacturer.

13	Motor HALL failure	Turn off the system power, check if the motor sensor plug is loose or dropped off, restore it and restart the system. If it still does not work, please replace the controller and inform the manufacturer.
14	DSP Read/Write EEPROM failure	Try another time after power down, if it still does not work, please replace the controller and inform the manufacturer.
15	Motor over-speed protection	Turn off the system power, turn on again in 30 seconds to see if it works. If not, try several more times, if such failure happens frequently, please change the controller and inform the manufacturer.
16	Motor reversion	Turn off the system power, restart the system after 30 seconds, if it still does not work, please replace the controller and inform the manufacturer.
17	HMI51 Read/Write EEPROM failure	Turn off the system power, restart the system after 30 seconds, if it still does not work, please replace the controller and inform the manufacturer.
18	Motor overload	Turn off the system power, restart the system after 30 seconds, if it still does not work, please replace the controller and inform the manufacturer.
19	Lack of oil alarm	Add oil to the needle rod, and set the P22 parameter at 4000, resume the working time after the last oil adding; or you can press button P to close the alarm and continue to use.

386P0064A

2012-11-19