

Automatic sewing machine Servo controller instructions



Preface

 CAUTION:	Please read this manual carefully, also with related manual for the machinery before use the controller. For installing and operating the controller properly and safely, qualified personnel are required.
---	--

This product is designed for specified sewing machines and must not be used for other purposes.

If you have any problem or any comment, please feel free to contact us.

Safety Instruction

- (1) All the instruction marked with sign  must be absolutely observed or executed; otherwise, personal injuries or risk to the machine might occur.
- (2) This product should be installed and operated by persons with appropriate training only.
- (3) Before connecting power supply cords to power sources, it's necessary to make sure that the power voltage is in the range indicated on the product name plate.
- (4) Make sure to move your feet away from the pedals while power on.
- (5)  Turn off the power and remove plug prior to the following operations:
 - Connecting or disconnecting any connectors on the control box;
 - Repairing or doing any mechanical adjustment;
 - Threading needle or raising the machine arm;
 - Machine is out of work.
- (6) Make sure to fasten all the fasteners firmly in the control boxes prior to the operation of the system.
- (7) Allow an interval of at least 30 seconds before repapering the system after power off.

- (8) Repairs and maintenance work may be carried out by special trained electronic technicians.
- (9) All the replacement parts for repairing must be provided or approved by the manufacturer.
- (10) The controller must be firmly connected to a properly grounded outlet.
- (11) Ground wire installation (special attention).

	CAUTION: Be sure to connect the controller to a properly grounded outlet. If the grounding connection is not secured, you may run a high risk of receiving a serious electric shock, and the controller may operate abnormally.
---	--

1. Basic parameters

Controller Type	AKD58-50
Max. Sewing Speed (r/min)	7000
Voltage Range	AC 220±20% V 50/60HZ
Output Power	550W
Max. Torque	3.5Nm
Environment	0°C ~ 40°C

2. Secure wiring and grounding

The system is powered and ready for use, you must ensure that the AC input is securely grounded (Figure 2-1). System grounding wire is yellow and green lines, make sure the ground wire securely connected to the machine head (such as connecting to the head of the screw), in order to ensure the safe use, and prevent abnormal situation

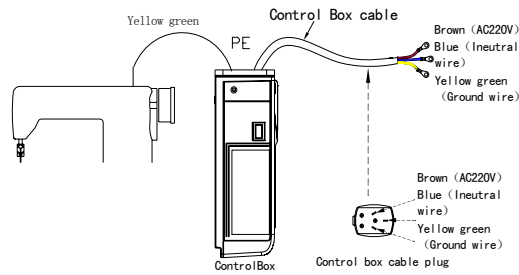



Fig.2 -1 Controller power wiring diagram

 CAUTION	<p>Ensure all power cord, signal wire and grounding wire not be pressed by other matter or over-twisted ,and not be too close to belt and belt wheel, keep 3cm-distance for safety.</p>
--	---

A 1Φ/220V power from a 3Φ/380V Power source Connection (See Fig.2-2):

 CAUTION	<p>If the system have no Neutral point, then this servo motor is not suitable for this connection.</p>
---	--

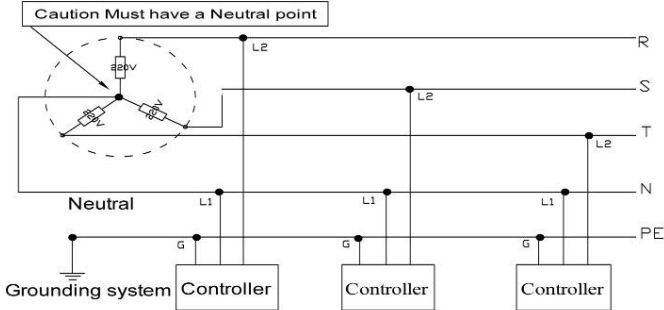

Fig. 2-2 Three-phase power wiring diagram

3. Definition of controller interface

Connections between control box and other accessories are illustrated in Fig.3-1.

Plug these connectors into the corresponding sockets in control box.

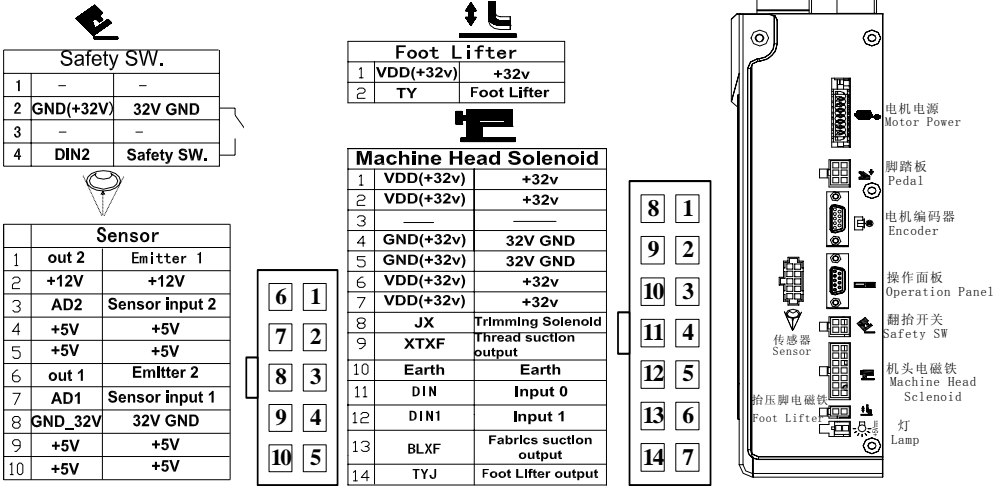



Fig.3-1 The controller of interface schematic diagram

*** The drive ability of the LED jack:**

Which the rated current is 100mA and the rated voltage is 5V, the output current is adjustable.
 Recommendatory LED diode parameter as follows:
 VF: Min. = 3.0V, Max. = 3.6V (test condition IF = 20mA);
 Peak Forward Current: Max. = 80mA;
 Continuous Forward Current : Max. = 35mA

	Caution: Please check if all connectors match or not, pins are found right definition or not.
---	--

4. Operation Panel Instruction

4.1 Appearance and key

The front operation panel (See Fig4-1) is provided with a status indicator divided, LCD display area and keys operation area.

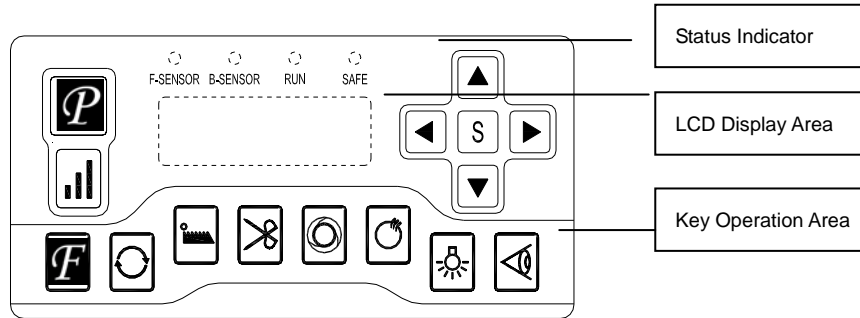

















Fig.4-1 Automatic bag sewing Chinese panel display

There are 13 keys in the key operation area that used to set the over lock sewing machine kinds of operation control parameters. There are 4 display lights at the top of the Panel that used to display real-time it operating status. F-SENSOR lights and B-SENSOR lights indicate front edge sensor and back sensor to status, light is lit indicate cloth cover sensor, light is not lit indicates that the sensor is not blocked; RUN light is lit indicates the rotation of the motor running; SAFE light is lit indicates a safety switch open. Table 2 shows function of each key.

Table2: Following form is the instruction of each key:

No	KEY	Description
1		Main menu key: Return to the main interface, or work with other key.

2		Automatic mode selection keys: The sensor is open, pressed in succession followed by optional automatic or semi-automatic mode.
3		Suck selection keys: When sewing is selected suction mode, continuous press are optional before suction, back suction, before and after suction ,and suck the closure of four modes.
4		Speed selection key: To set the maximum sewing speed.
5		Trimming selection key: When sewing is selected trimming mode, continuous press are optional front trimming, back trimming, front and back trimming ,and trimming the closure of four modes
6		Edge mode selection key: When sewing is selected working mode of mop wheel, continuous press are optional before mop wheel, rear mop wheel, before and rear mop wheel ,and the mop wheel closure of four modes.
7		Save to determine key: To save the parameters set.
8		Up arrow keys: When setting parameters, increasing the value at the cursor.
9		Down arrow keys: When setting parameters, decreasing the value at the cursor.
10		Left arrow key: When setting parameters, move the cursor to the left; Front trimming length shortcuts.
11		Right arrow key: When setting parameters, move the cursor right; Back trimming length shortcuts.
12		Machine headlight key: To adjust machine headlight brightness, followed by optional 0-4 consecutive press.
13		Sensor selection key: To open or close the electric eye. Electric eye closure enters full manual mode, the sensor does not work; to open electric eye sensor is working, and then enter the semi-automatic mode or fully automatic mode.
14		Speed selection key: To set the maximum sewing speed.
15		Special function keys: User-defined extensions settings.

4.2 The main interface and function key setting

The control panel is correctly inserted corresponding interface electrical control box; confirm security turn on the power. Boot for about 2 seconds, the LCD will display the

main interface, shown in Figure4-2. If it is not a normal display and a fault alarm, please refer to Chapter 3 false alarms table, deal with the corresponding failure or contact the manufacturer.

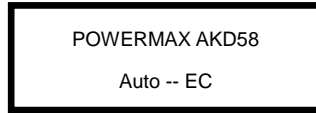

Fig. 4-2 System main interfaces

































In Fig. 1-2 system main interface, press the  key, then displays the current settings for automatic sewing machine working status, shown in Fig.4-3.





Fig. 4-3 the current operating mode

Wherein, the icon  shows electric eye switch status, the icon  shows the current trimming mode, the icon  shows the current mop wheel mode, the icon  shows the current suction mode. Press the  key to return to the main interface. If you do not operate for about 10 seconds, the system will automatically return to the main interface mode.

In the main interface (show to fig.1-2), respectively press the function key (, , , , , , , , , , , , , , , , , , , , , , , , , , , ,

the foot control electric eye sensor control automatic presser foot, by the foot pedal before starting sewing. During sewing foot pedal will be suspended after the sewing step before proceeding to continue automatic sewing processes. Automatic mode is entirely controlled by the electric eye sensor to sewing machine is running automatically, this time electric eye open, pedals do not control the sewing machine, the timing of each function only by the electric eye automatic detection and control.

Table3: overlock sewing pattern corresponding relationship

Sewing mode	Electric eye on or off 	fully automatic mode selection 
full manual mode	off	invalid
semi-automatic	on	semi-automatic
automatic electric control	on	automatic electric control
automatic foot control	on	automatic foot control

Example: If the current to full manual mode, the actual status at this time electric eye switch is off, the main interface shown in Figure 4-4.

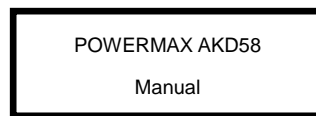



Fig. 4-4 full manual system main interface

Press the  key, then displays the current state of electric eye switch, shown in Figure 4-5.

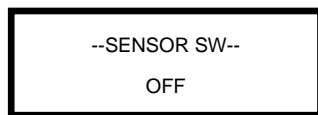



Fig.4-5 electric eye switch off



Fig.4-6 electric eye switch on

Press the  key again, electric eye switch immediately opens, displaying electric eye switch is turned on, as shown in Figure 4-6, then press the  key to confirm automatic sewing mode, if the current mode is automatic sewing mode, shown in Figure 4-7; when the current sewing mode is semi-automatic mode, shown in Figure 4-8.

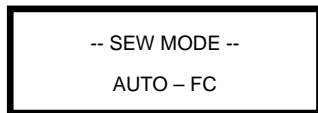

Fig.4-7 full automatic mode

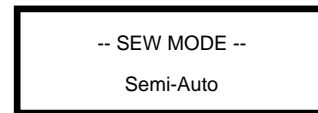



Fig.4-8 semi-automatic mode

In the current electric eye switch remains open in the case, press the  key, in fully

automatic and semi-automatic mode switching. After it is set, press the **P** key to exit.

4.4 The maximum speed setting

Press the **▲** key, then the system will run set to the current maximum speed shown in Figure 4-9.

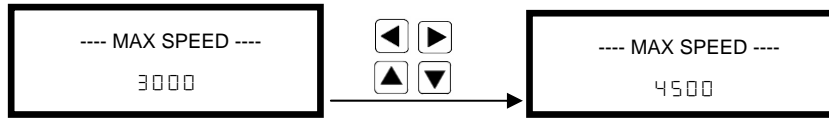

Fig. 4-9 system current maximum speed

Fig. 4-10 set system maximum speed

Then you can use the keys to move the cursor, keys to change the number, the maximum speed is displayed after the change shown in Figure 4-10. After setting, press the key to exit.

4.5 Front and back trimmings length shortcuts of adjustment

In the main interface, the **◀**, **▶** key can be respectively front and back trimmings length shortcuts adjustment, **▲**, **▼** key to change the numbers, which will be effective simultaneously. As shown in figure 4-11.

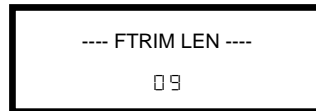

Fig. 4-11 Front and back trimmings length setup

4.6 Sensor sensitivity automatic detecting function

Before using this function, please make sure that the bed is no cloth and all sensor surface with no dust and thread occlusion. Then in the main interface system (which is valid only in the interface), long press the **F** key interface will jump, release it to enter the sensor sensitivity function of automatic detection, As shown in figure 4-12.

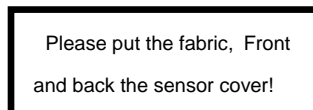
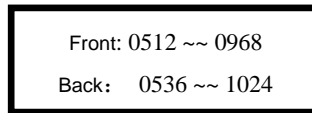

Fig. 4-12 The sensor sensitivity of automatic detection enter to interface

Please follow the prompts the fabric placed on the bed, and completely covers front and back sensor, system according to the fabric thickness shows the sensitivity of maximum and minimum value, such as a fabric is shown below:



Front: 0512 ~~ 0968
Back: 0536 ~~ 1024

Fig. 4-13 The sensor sensitivity of maximum and minimum value

After successful completion, the system will prompt the user to remove cloth, can work normally. The following:

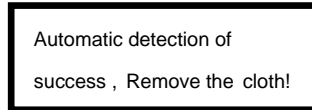

Automatic detection of
success , Remove the cloth!

Fig. 4-14 The sensitivity automatic of success

4.7 The fabric suction mode of quick adjustment

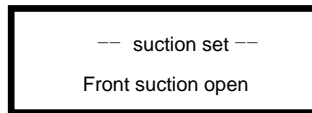

Press  enter to suction mode setting, The fabric suction mode quick adjustment.

As shown in the figure below (in an air suction mode are available):



-- suction set --
Front suction open

Fig. 4-13 The suction mode setting interface

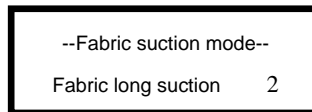

At this time, press 、,key can enter to fabric suction of quick adjustment

interface wind patterns, such as the display:



--Fabric suction mode--
Fabric long suction 2

Fig. 4-14 The fabric suction mode interface

After entering, through 、key to change the numerical suction mode of different fabric selection, a total of three species, such as:

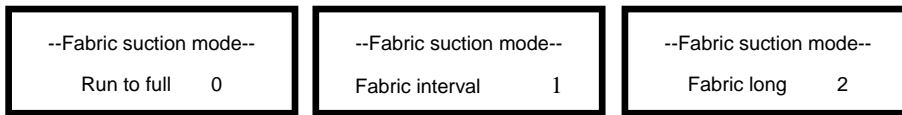

Fig. 4-15 The fabric suction of three species

5. Advanced Features

5.1 Conversion between the Chinese and English

In the main interface, press **P** key + **F** key to complete the switch in English, as shown in Figure 5-1 and 5-2, press **P** key + **F** key to switch back to the Chinese interface.

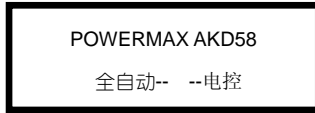

Fig.5-1 chinese interface



Fig.5-2 english interface

5.2 Technicians parameter settings

In the main interface under, press **P** key + **↵** key, to enter the technician parameter setting's password interface, shown in Figure 5-3.

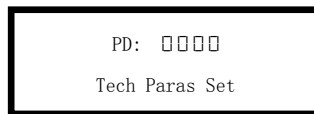

Fig.5-3 password interface

Technician's parameter password can press **←** and **→** keys to move the cursor, press **▲** and **▼** keys to change the number, the initial password is □□□□. Enter the correct password; press the **S** key to enter the machine repair parameter settings shown in Figure 5-4.

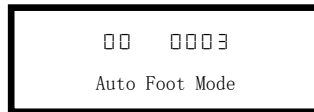

Fig. 5-4 the machine repair parameter settings

Figure 2-4 shows the current system parameter list. The before two digits of the parameter number, the last four digits of the parameter value. Text below the parameter's instructions. You can press **←** and **→** keys to move the cursor, press **▲** and **▼** keys to change the number, select the number of different parameters and setting the corresponding parameter values. If you need to save and exit, press **S** key, otherwise press **P** key.

5.3 Restore factory settings

In the main interface, press **P** key+ **◀** key, enter the correct password, press **S** key to enter the technician parameters. Select the **62** parameters and corresponding values to **2008**, shown in Figure5-5.

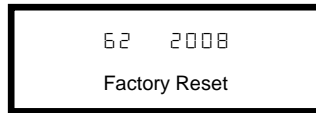

Fig.5-5 Parameter reset to factory

In Figure 5-5 interface, press **S** for two seconds until the screen show in Figure 5-6, wait for about 5 seconds, the buzzer rang long after the recovery is complete(Hint: the recovery process should not turn off the power or unplug the panel!). After the completion of the operation is proposed to re power on reset time.

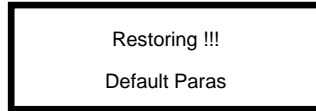

Fig.5-6 Parameter reset to factory

5.4 Automatic test mod

In the main interface press **P** key+ **S** key to enter the automatic test setup interface, you can press **◀** and **▶** keys to switch running time, stop time, test time, press **▲** and **▼** keys to change the corresponding figures. Running time, stop time in units of 0.1 seconds, the unit test time is 10 minutes.



Fig.5-7 the main interface

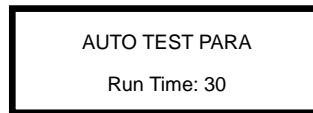
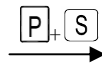

Fig.5-8 automatic test parameter setting interface

In Figure 5-8 interface, press **P** key+ **S** key again, which enters the automatic testing process, shown in Figure 5-9, then light foot pedalling to start the automatic test.

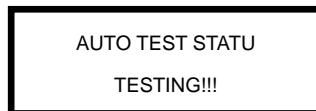

Fig.5-9 automatic test run interface

To exit test mode to run automatically, you can press **P** key+ **S** key, the motor stops running, the automatic end of the test and return to Figure 5-8 interface, press

the **P** key again to return to the main interface.

5.5 Monitor Mode

In the main interface, press **P** key+**⊗** key to enter monitor mode, you can view the current system parameters, the specific content shown in Table4.

Table4: monitor mode parameter

	Parameter No.	Comment
Monitor status	10	Counter stitches
	11	Counter trimming
	20	DC Bus Voltage
	21	Motor speed
	22	One phase current
	23	Initial angle
	24	Mechanical angle
	25	Sampling value of pedal voltage
	26	Motor/machine head run ratio
	27	Motor total run time
	28	Sampling value of potentiometer at machine head
	29	DSP Software version number
	30-3F	History Error Code Recorder 8

6 Technician parameter setting

In the main interface, **P** key+**⏪** key to enter the technician parameters, Table 5 can view and modify the parameters, mainly the system speed, a variety of automatic feature set, pedal settings and parameters transfer functions.

Table 5: Technician mode parameter:

	Parameter byte	Default	Rang	Comment
speed	00	1	0-3	Auto foot lifter setup:0 off ; 1 Before foot lifter; 2 Back foot lifter; 3 Before and Back foot lifter
	01	0	0/ 1	Speed mode: 0 automatic; 1 pedal control speed
	02	0	0/ 1	The needle stop position: 0 up needle position; 1 down needle position

	Parameter byte	Default	Rang	Comment
	03	0	0/1	Foot lifter setup when the needle stop in the middle position: 0 off; 1 automatic foot lifter
	04	1	0/1	Manual stitch suck mode: 0 off; 1 on
	05	3000	200-4200	Automatic sewing speed
	06	5000	400-6500	Maximum sewing speed
	07	1	0/1	Semi automatic continuous sewing: 0 automatic stop back trimming ; 1 Tread the pedal for sewing
	08	2	0/1/2	Semi automatic constant speed: 0 Full constant speed; 1 The pedal control it when the two sensor is effectively at the same time; 2 Full pedal control
	09	200	100-800	Minimum speed
	0A	300	100-800	Treading needle speed (retain)
Automatic function setup	10	20	0-50	Front sensor operation and effective number of stitches (front sensor sensor automatically go pin number, completed after the sensor still no sense if you stop pin)
	11	20	1-50	Number of needle between the two sensors (front sensor signal disappeared, after the sensor is sensed to continue sewing needle;
	12	2	1-50	The before Trimming delay needle (FB = 11 signal start count needle)
	13	9	1-50	The back Trimming delay needle (FB = 00 signal start count needle)
	14	1	1-50	The before suction start needle (FB = 10 signal start count needle)
	15	0	0-5000	The before suck delay time (ms)
	16	1	1-50	The back suction start needle (FB = 00 signal start count needle)
	17	300	100-5000	The back suck off delay time(ms)
	18	1	0-1	Suck mode: 0 when the motor is running long suction; 1 automatic mode suction

	Parameter byte	Default	Rang	Comment
	19	200	100-5000	When it is running suction of delay time, long suction can be back stepped or manual trimming Close
	1A	3000	0-5000	Automatic mode is completed, parking, needle of number running speed
	1b	10	10-5000	Start sewing delay time (Retain)
	1C	10	1-99	Stop delay pins (rear sensor signal disappeared after count sewing needle number,FB = 00 signal begins to count)
	1d	10	0-99	Automatic mode is completed, parking, rear number of stitches
	1E	500	0-5000	Automatic mode is completed, parking, walking up the end of the solenoid valve A new opening time ms
	1F	500	0-5000	New solenoid valve A is closed,new solenoid valve B is open , open time ms
Peripheral function setup	20	10	1- 1000	The before sensor response time
	21	680	0- 1024	The before sensor sensitivity (According translucent fabric manually adjust the sensitivity of sensor)
	22	680	0- 1024	The back sensor sensitivity (According translucent fabric manually adjust the sensitivity of sensor)
	23	280	10-2000	The before foot lifter retention time (FB = 10singal begins to count)
	24	1	1-2000	The back foot lifter start up delay time(back trimming stop ,it begins to count)
	25	3	1-600	Foot lifter protection time 100ms
	26	30	20-800	The before foot lifter stop of delay time(ms) (press down foot to start sewing the interval)
	27	0	0 / 1	Automatic mode recognized work cycle : 0: After trimming before halfway out of the cloth, not after trimming action, once again put the cloth will not be executed before the cut line, until after the cut line, be considered a work cycle ends.

	Parameter byte	Default	Rang	Comment
				1 : Regardless of whether the thread trimming after completion, as long as the cloth out, are recognized as a work cycle. Again into the fabric, which began a new working cycle and run before trimming
	28	0	0 / 1	It is running manual trimming: 0 off; 1 on
	29	1	0 / 1	Safety switch: 0 off; 1 on
	2A	70	1- 1000	Trimming keep start time
	2b	20	1-20	Acceleration sensitivity (direct drive head can be set to a larger value; belt drive can not be set too big, otherwise
	2C	20	1-20	Deceleration sensitivity (The direct drive head can be set to a larger value; The belt drive can not be set too big, otherwise vibration, noise is big. The parameter does not affect the motor output)
	2d	1000	200- 1200	The medium speed value (RPM)
	2E	50	25-200	The low speed value (RPM)
	2F	250	20-600	Full manual mode foot lifter delay time ms
operational control	3A	100	0 ~800	Pedal press foot lifting confirm time
	3b	1	0 / 1	Run to up needle position after Power on: 0: no action 1: action
	3C	0	0 / 1 / 2 / 3	Special operating modes: 0: Operator mode (common functions) 1: Simple sewing mode (no needle stop up or down) 2: Measured motor initial angle (no need to remove the belt) 3: Calculate the gear ratio mode (requires needle sensor, and can not take off the belt)
	3d	0	0~31	Torque boost up at low speed : 0: no action 1~31: 31 levels Torque boost up

	Parameter byte	Default	Rang	Comment
	3E	1	0 / 1	Stop pin mode : 0: Constant speed tackle mode (in the belt transmission, Parking is not precision) 1: back pull mode (PMX)
Operation	60	0		It is running time reset
	61	1	0 / 1 / 2	Translating Parameter 0: no action 1: Download parameters(the panel will parameter from panel to controller) 2: Upload parameters (the panel will parameter from controller to panel)
	62	-	-	Restore storage parameter(Only restore parameters to operators, and vendors and maintenance)
	63	0	1/2	Backup current parameter as user parameter for restore (restore)

7 Recovery processing and maintenance

Table 6: Error handling and maintenance

error code	meaning	error code	meaning
01	hardware overflow	11	machine head needle positioning failure
02	software overflow	12	motor original angle checking failure
03	system under-voltage	13	Motor HALL failure
04	over-voltage when the machine is off	14	DSP Read/Write EEPROM failure
05	over-voltage in operation	15	Motor over-speed protection
06	solenoid circuit failure	16	Motor reversion
07	electrical current checking circuit failure	17	HMI51 Read/Write EEPROM failure
08	locked motor roller	18	Motor overload
09	brake circuit failure	20	Lack of oil alarm
10	HMI communication failure	21	Sensor error

386P0116C

2014-2-19